

pewiSYS

**material
handling**

Load- & unloading system
Box & bags handling system
Pallet handling system
Floor chain transport system
Others



pewiFLEX™ Multifunctional powered flexible roller conveyor

Benefit pewiFLEX™

Cost reducing by:

- Efficient use of personnel (increasing labour productivity)
- Health and Safety friendly
- Multifunctional to use because of flexibility and movability

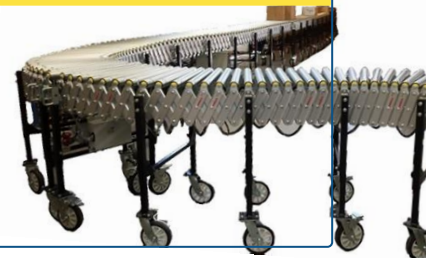

Specification pewiFLEX™

- Roller width 460mm, 610mm or 760mm
- Zinc plated rollers, diameter Ø50mm
- Standard pitch at max. opening : 130mm
- Start stops per hour: max. 400/hour
- Capacity construction 250 kg/meter
- Capacity load to start up 150 kg/meter
- Casters, front, middle and end side are provided with brakes
- Caster diameter 178 mm x 45 mm (7" x 1,7")
- Start/stop and emergency stop on front and end of pewiFLEX™
- Speed adjustable from 0 → 40 m/min by inverter
- Monophasic 240 Volt, 50 Hz, two directions
- Height adjustable from 730 / 900mm (top part rollers)



**Sturdy wheels
with and without brake**

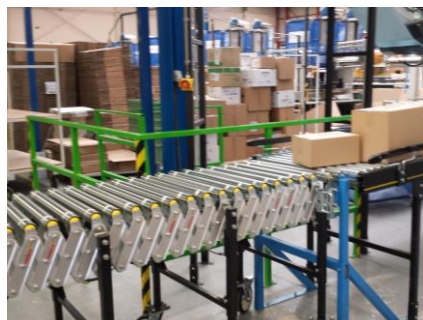

www.pewisys.nl

pewiSYS material
handling bv

Kalkoenweg 40
3851 SC Ermelo

T +31 (0) 341 76 81 10
F +31 (0) 241 55 01 25

E info@pewisys.nl
W www.pewisys.nl

Options pewiFLEX™

- Roller pitch max. opening : 67mm or 102mm
- pewiJOINT™ connection unit
- Retractable end stop
- pewiFLEX™ Impact unit
 - length 780mm, provided with double LED lighting
- pewiLIGHT™, lighting unit with retractable roller end stop
- Sensor beam placed between 2 rollers
- 3 phase 380 Volt
- Different length, width and height on request



pewiFLEX™ type 50				
Roll diameter 50 mm steel zinc plated				
TYPE				
		Compact length	Max. length	
Roller length	460 mm	PEW 50-46-08	3,51 m	8,34 m
		PEW 50-46-11	4,66 m	11,09 m
		PEW 50-46-13	5,82 m	13,83 m
		PEW 50-46-15	6,58 m	15,66 m
610 mm	PEW 50-61-08	3,51 m	8,34 m	
	PEW 50-61-11	4,66 m	11,09 m	
	PEW 50-61-13	5,82 m	13,83 m	
	PEW 50-61-15	6,58 m	15,66 m	
760 mm	PEW 50-76-08	3,51 m	8,34 m	
	PEW 50-76-11	4,66 m	11,09 m	
	PEW 50-76-13	5,82 m	13,83 m	
	PEW 50-76-15	6,58 m	15,66 m	

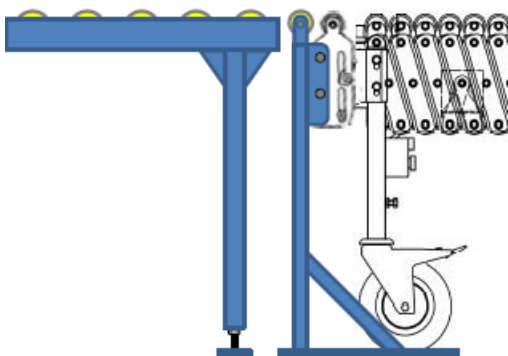

pewiJOINT™ connection unit



pewiFLEX™, impact unit



pewiLIGHT™, lighting unit.

also to use for pewiGRAFLEX™